

FICHE D'HOMOLOGATION / HOMOLOGATION FORM

033-CH-29



COMMISSION INTERNATIONALE DE KARTING - FIA



CADRE DU CHÂSSIS / CHASSIS FRAME MINI

Constructeur / <i>Manufacturer</i>	LENZOKART s.r.l
Marque / <i>Make</i>	LENZOKART
Modèle / <i>Model</i>	CAYMAN
Catégorie / <i>Categorie</i>	Group 3
Durée de l'homologation / <i>Validity of the Homologation</i>	4 ans / 4 years
Nombre de pages / <i>Number of pages</i>	3
La présente Fiche d'Homologation reproduit descriptions, illustrations et dimensions du cadre du châssis au moment de l'homologation CIK-FIA.	<i>This Homologation Form reproduces descriptions, illustrations and dimensions of the chassis frame at the moment of the CIK-FIA homologation.</i>

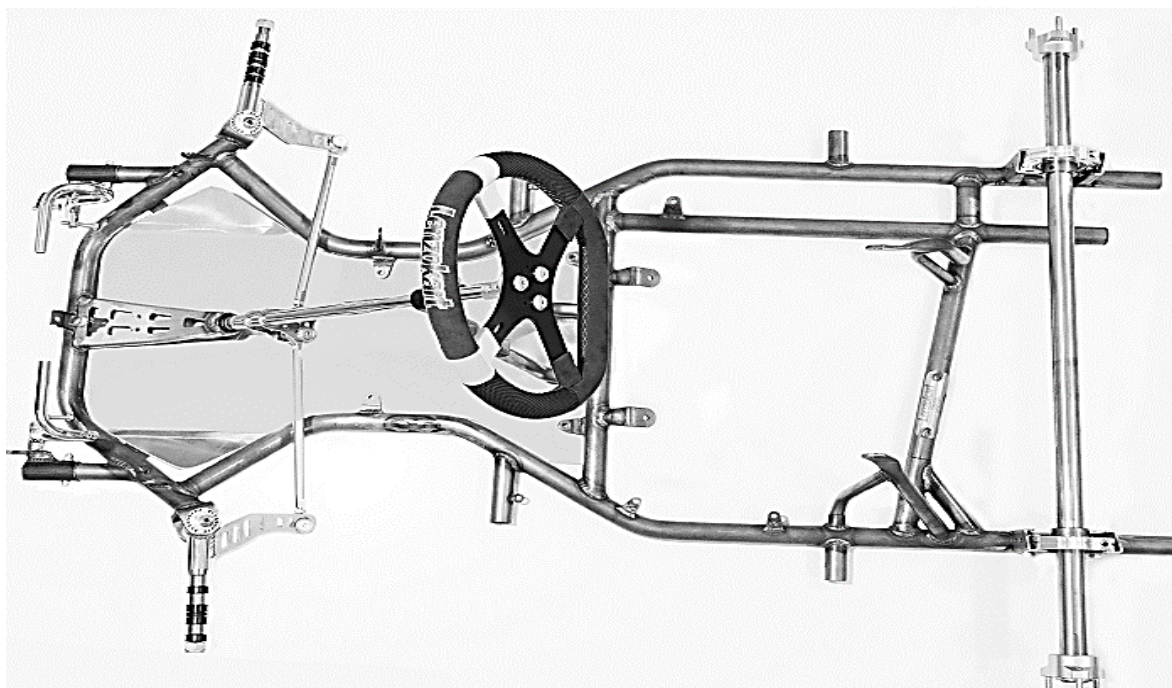

Photo du de dessus du châssis complet identique à l'un des modèles présentés à l'homologation sans pare-chocs, freins, carrosserie, siege ni roues. /
Photo from above of complete chassis identical to one of the models submitted for homologation without bumpers, brakes, bodywork, seat or wheels.

Signature et tampon de l'ASN /
Signature and stamp of the ASN

Signature et tampon de la CIK-FIA /
Signature and stamp of the CIK-FIA



A

Dessin technique du cadre / Technical drawing of frame

Le dessin technique (Échelle 1:10) sert pour identifier la structure et la géométrie du cadre. /
 The technical drawing (Scale 1:10) is used for the identification of the structure and the geometry of the frame

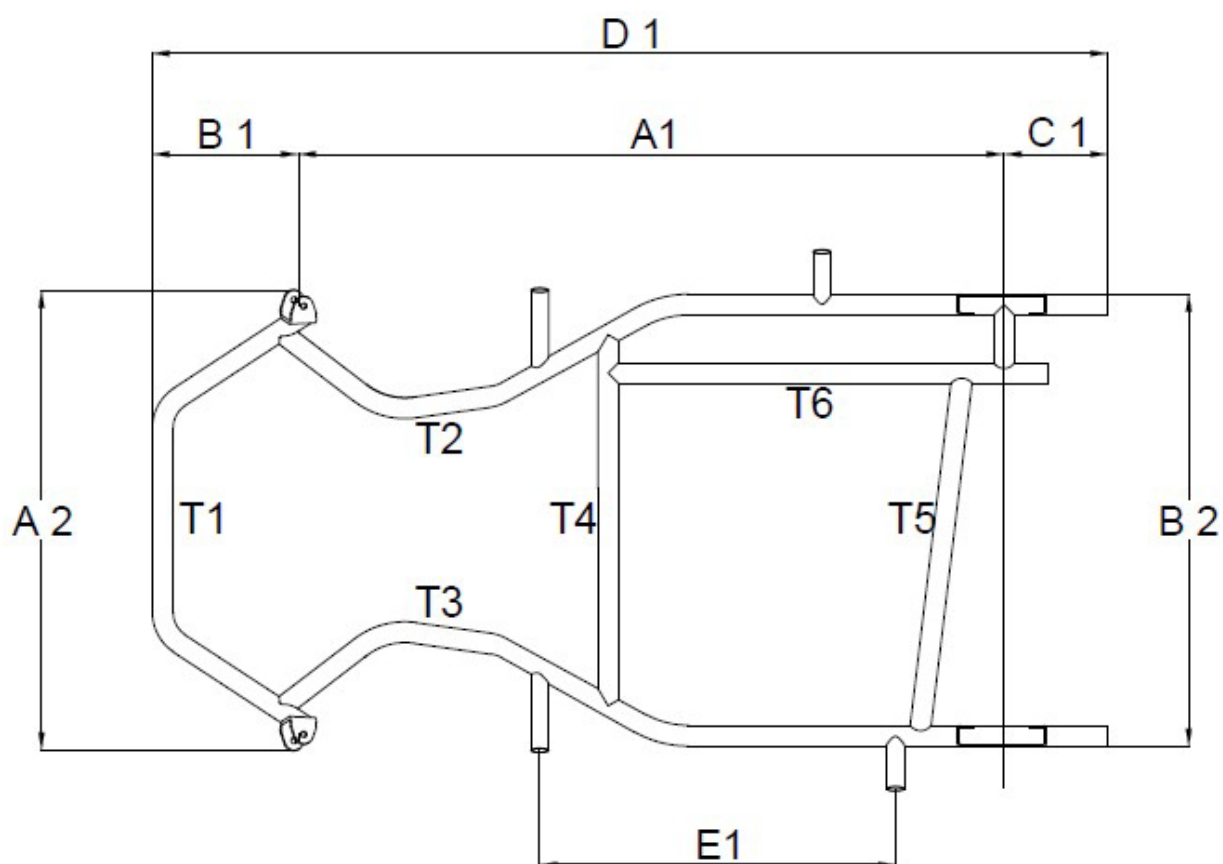
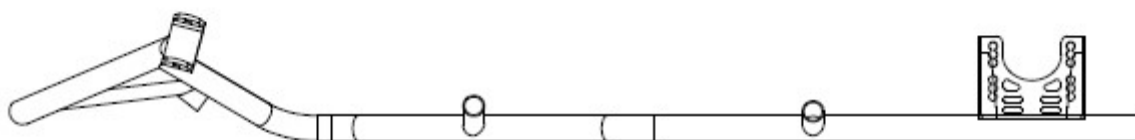
Vue de dessus / View from above**Vue de côté / Side view**

B	Cotes / Dimensions		
Cadre / Frame	Dimensions / Dimensions	Tolérances / Tolerances	
A1 = Empattement / <i>Wheel base</i>	950 mm	± 5 mm	
B1 = Porte-à-faux avant / <i>Front overhang</i>	200 mm	± 15 mm	
C1 = Porte-à-faux arrière / <i>Rear overhang</i>	130 mm	± 15 mm	
D1 = Longueur total / <i>Overall length</i>	1280 mm	± 15 mm	
E1 = Fixation pare-chocs latéraux / <i>Fixation side bumpers</i>	380 mm	± 5 mm	
A2 = Largeur avant extérieure / <i>Outer front width</i>	645 mm	± 10 mm	
B2 = Largeur arrière extérieure / <i>Outer rear width</i>	590 mm	± 10 mm	
T = Nombre de tubes / <i>Number of tubes</i>	6		
Nombre des courbes dans les tubes / <i>Number of bends on the tubes</i>	8		
Diamètre de tubes / <i>Diameter of tubes</i>	Ø28 mm		

C	Photo du marquage du numero d'homologation / Photo of the homologation number marking
	
<p>Le marquage indiqué sur le tube transversal arrière doit rester clairement visible en permanence / <i>The marking located on the rear strut must be clearly visible at all times</i></p>	

D	Photo de la commande de freinage / Photo of brake control cable
	
<p>La commande de freinage doit être isolée du châssis et montrer la double commande / <i>The brake control must be separated from the chassis and show the double linkage</i></p>	